

BLACK OR DARK OLIVE GREEN

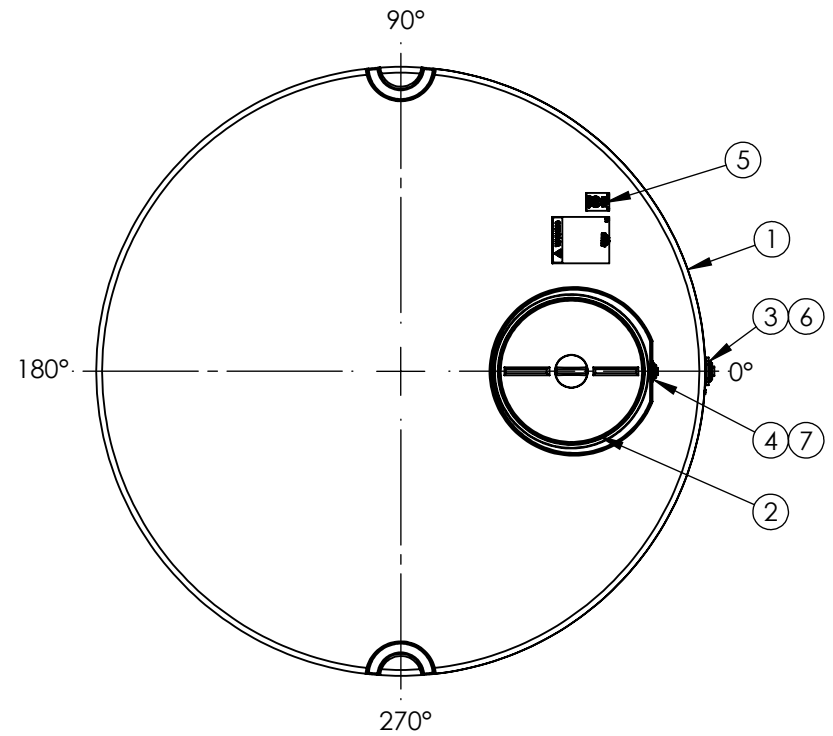
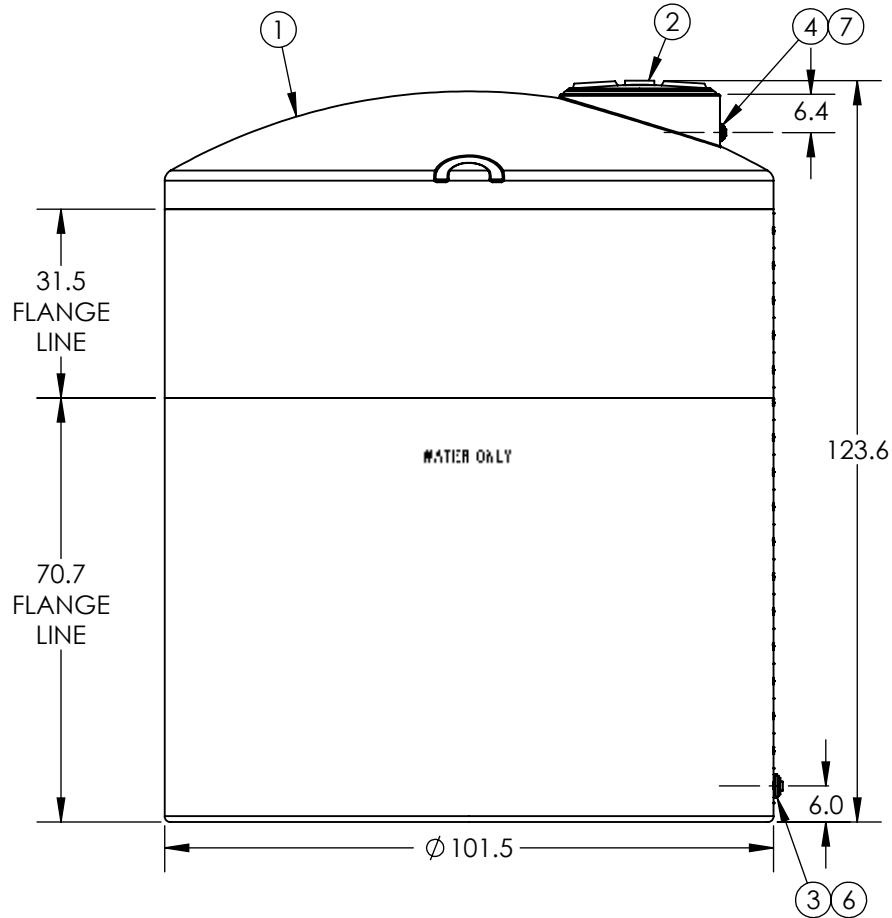

7	1	64149	1-1/2" NPT PLUG
6	1	60021	2" NPT PLUG
5	1	99700231	DECAL NSF MARK - WATER TKS
4	1	63931	FTG PP 1-1/2IN ECO-BH EPDM TXT
3	1	60405	FTG PP 2IN BH EPDM TXT
2	1	34700352	ASM MANWAY PE 24IN VENTED
1	1	1009100W__02	ASM TK 4100 X 102 WATER NH NOMW

ITEM NO.	QTY.	PART NUMBER	DESCRIPTION	
DO NOT SCALE		DRAWN BY	TITLE:	
Released		SB	 <b>ASM TK 4100VDT X 102 WATER</b>	
© SNYDER INDUSTRIES INC., 2016		(402) 467-5221 www.snydernet.com	PART NO.	ENG. ID.
ALL DIMENSIONS, DESIGNS, AND INFORMATION ON THIS PRINT MUST BE CONSIDERED PROPRIETARY TO SNYDER INDUSTRIES, INC. AND MAY NOT BE USED, COPIED, OR DISTRIBUTED WITHOUT WRITTEN PERMISSION OF AN OFFICER (OR HIS AGENT) OF THE FIRM.			1009100W__03	D006369

REVISION  
**A**  
SHEET  
1 OF 1

**\*ALL EXTERNAL PIPING MUST BE INDEPENDENTLY SUPPORTED.**  
**\*ONLY BASE FITTINGS TO BE LEFT INSTALLED AT TIME OF SHIPMENT PER SII PROCEDURE.**  
**\*Consult Snyder's Guidelines for Use and Installation prior to delivery.**  
 Available on-line at <http://www.snyderindustriestanks.com/Technical>  
**ALL DIMENSIONS ARE IN INCHES, NOMINAL, & SUBJECT TO CHANGE WITHOUT NOTICE.**  
**ALL DIMENSIONS ON ROTATIONAL MOLDED PARTS ARE SUBJECT TO A ± 3% TOLERANCE.**