

BLACK OR DARK OLIVE GREEN

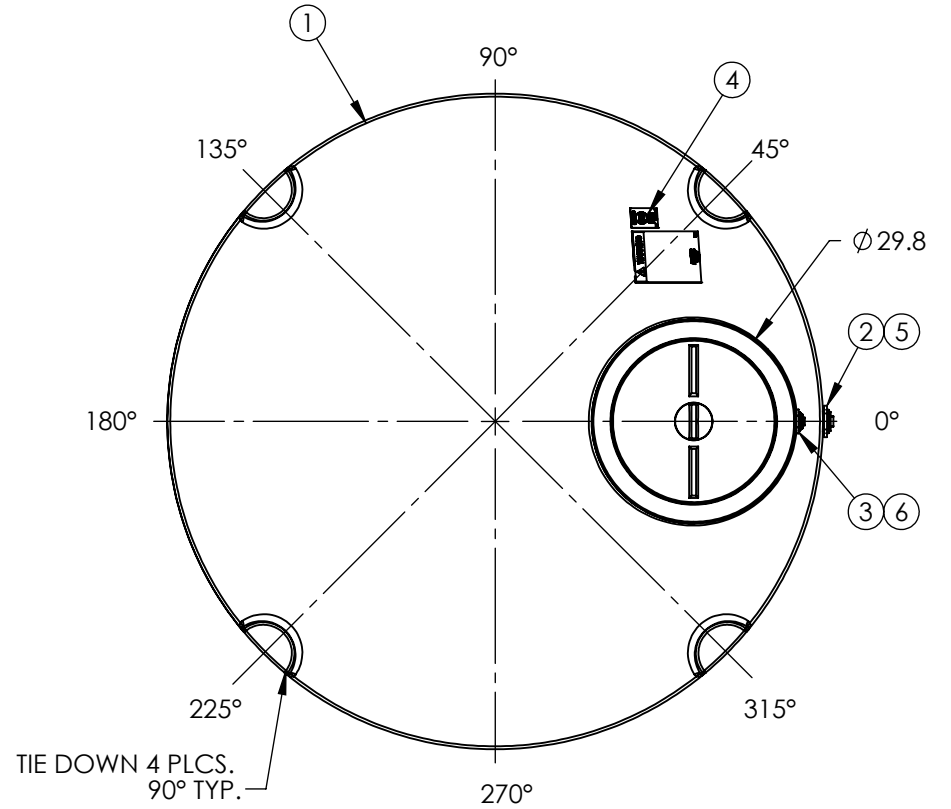
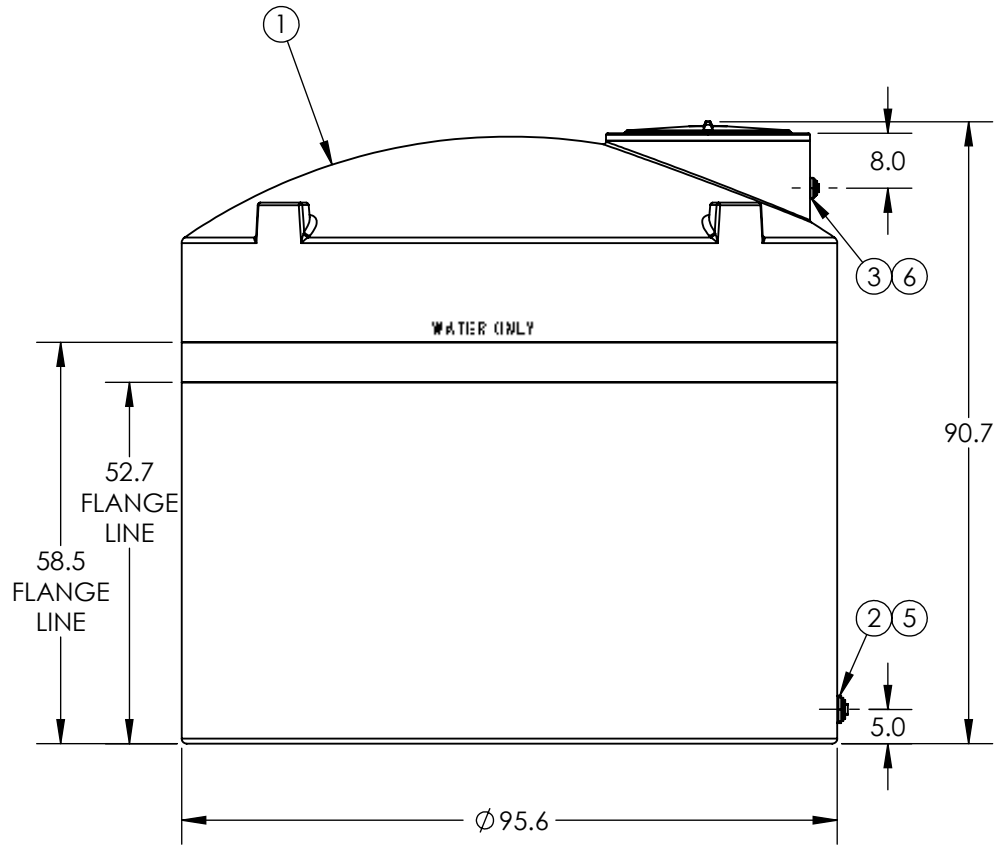

*ALL EXTERNAL PIPING MUST BE INDEPENDENTLY SUPPORTED.
 *ONLY BASE FITTINGS TO BE LEFT INSTALLED AT TIME OF SHIPMENT PER SII PROCEDURE.
 ALL DIMENSIONS ARE IN INCHES, NOMINAL, & SUBJECT TO CHANGE WITHOUT NOTICE.
 ALL DIMENSIONS ON ROTATIONAL MOLDED PARTS ARE SUBJECT TO A ± 3% TOLERANCE.

7	1	34700352	ASM MANWAY PE 24IN VENTED
6	1	64149	1-1/2" NPT PLUG
5	1	60021	2" NPT PLUG
4	1	99700231	DECAL NSF MARK - WATER TKS
3	1	63931	FTG PP 1-1/2IN ECO-BH EPDM TXT
2	1	60405	FTG PP 2IN BH EPDM TXT
1	1	5090200W__02	ASM TK 2600VDT X 96 WATER NH/NOMW

ITEM NO.	Default /QTY.	PART NUMBER	DESCRIPTION	
DO NOT SCALE		DRAWN BY	TITLE:	
Released		BH	 ASM TK 2600VDT X 96 WATER	
© SNYDER INDUSTRIES INC., 2016		(402) 467-5221 www.snydernet.com	PART NO. 5090200W__03	ENG. ID. D006336
<small>ALL DIMENSIONS, DESIGNS, AND INFORMATION ON THIS PRINT MUST BE CONSIDERED PROPRIETARY TO SNYDER INDUSTRIES, INC. AND MAY NOT BE USED, COPIED, OR DISTRIBUTED WITHOUT WRITTEN PERMISSION OF AN OFFICER (OR HIS AGENT) OF THE FIRM.</small>			REVISION B	SHEET 1 OF 1