

WATER

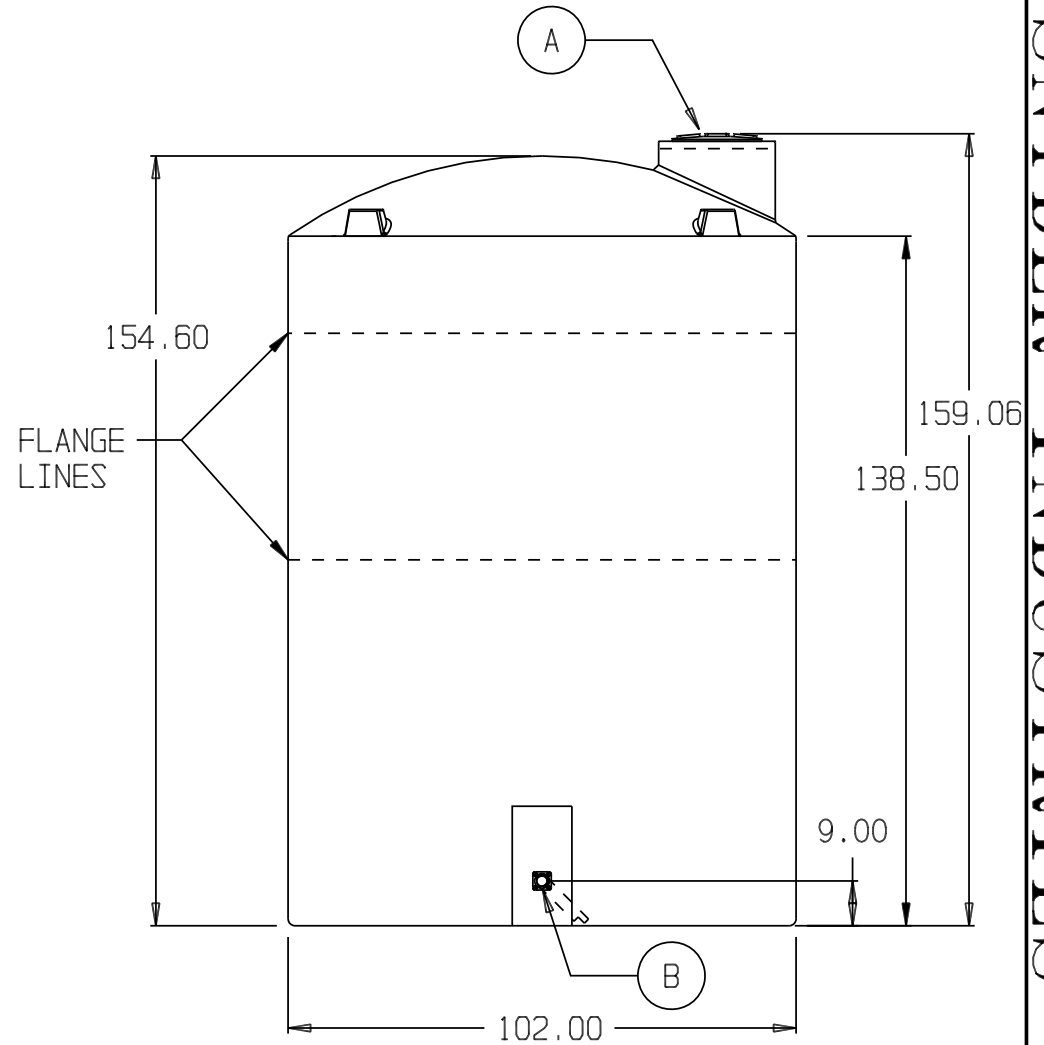
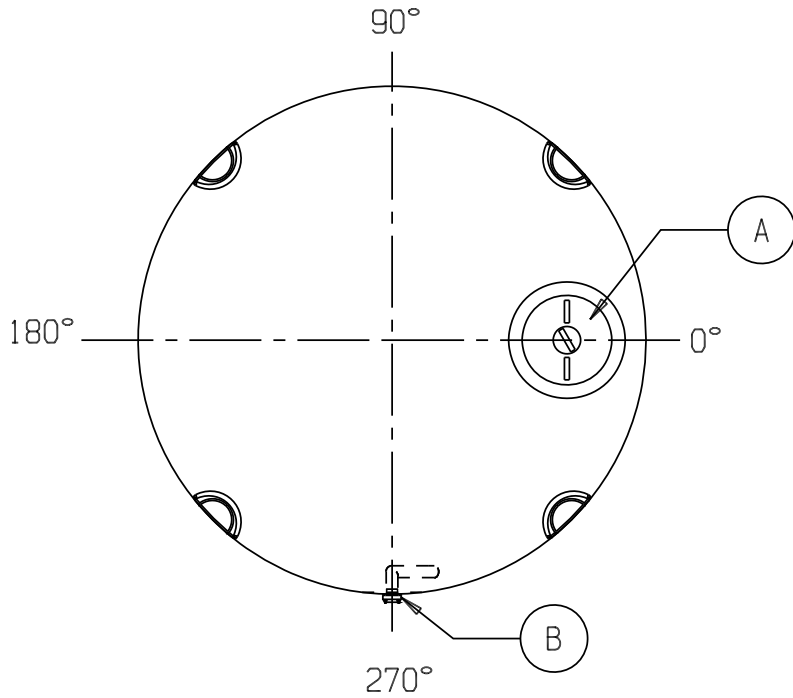

- A. 18" PE THREADED-VENTED MANWAY W/15" ACCESS [P/N 34700087]
- B. 2" PP DBL FLANGED BOLTED LONG SIPHON TUBE ASSY W/EPDM GASKETS & SS BOLTS [P/N 34700841]

BASE FITTINGS TO BE LEFT INSTALLED AT TIME OF SHIPMENT PER SII PROCEDURE

(all dimensions in inches)

PART # TANK: 7420100W943xx
HDLPE/NAT/WATER

REF#: 00000

04/08/09

5,000 GALLON VERTICAL WATER TANK

SNYDER INDUSTRIES INC.