

OVERALL DIMENSIONING

54.00" x 31.50" x 8.46"
137.2cm x 80.0cm x 21.5cm

PALLET FEATURES:

- WITH OR WITHOUT STEEL REINFORCEMENT (see next page)
- 4-WAY FORK-LIFT ENTRY
- FORKLIFT SAFETY STRAPS
- UNDER-DECK HANDHOLDS
- DECK-LOK SAFETY STACKING
- ROLL REMOVAL SLOTS
- TRIPLE STRETCH WRAP RETENTION WINGS

PATENT NUMBER/S:

US5606921, EP0725010, DE69603881,
USD433208S

**ALL DIMENSIONS ARE IN INCHES, NOMINAL, & SUBJECT TO CHANGE WITHOUT NOTICE.
ALL DIMENSIONS ON MOLDED PARTS ARE SUBJECT TO A ± 3% TOLERANCE, UNLESS SPECIFIED.**

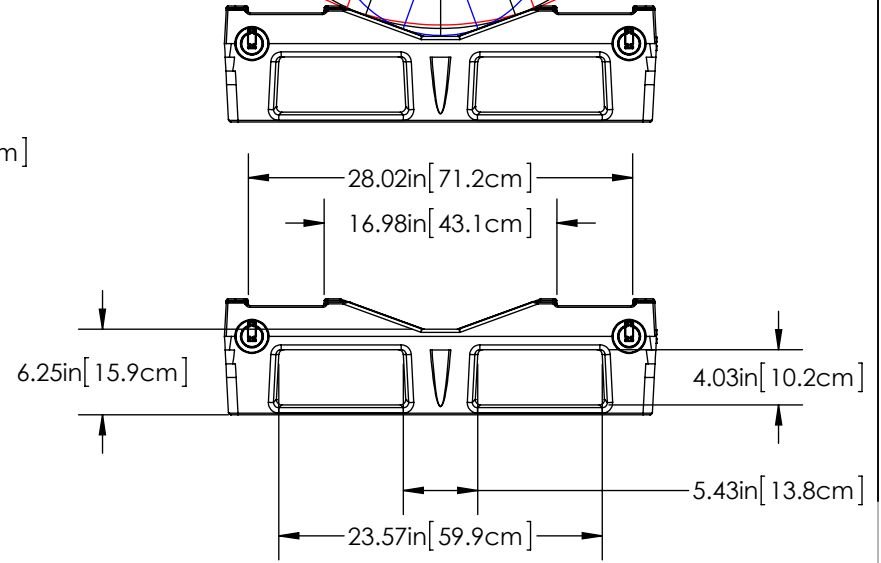
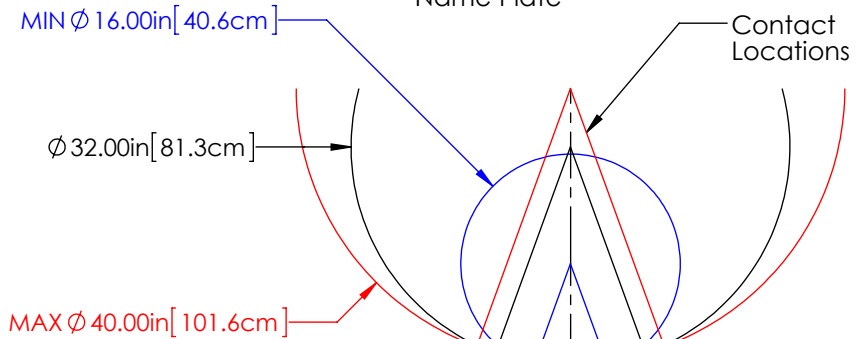
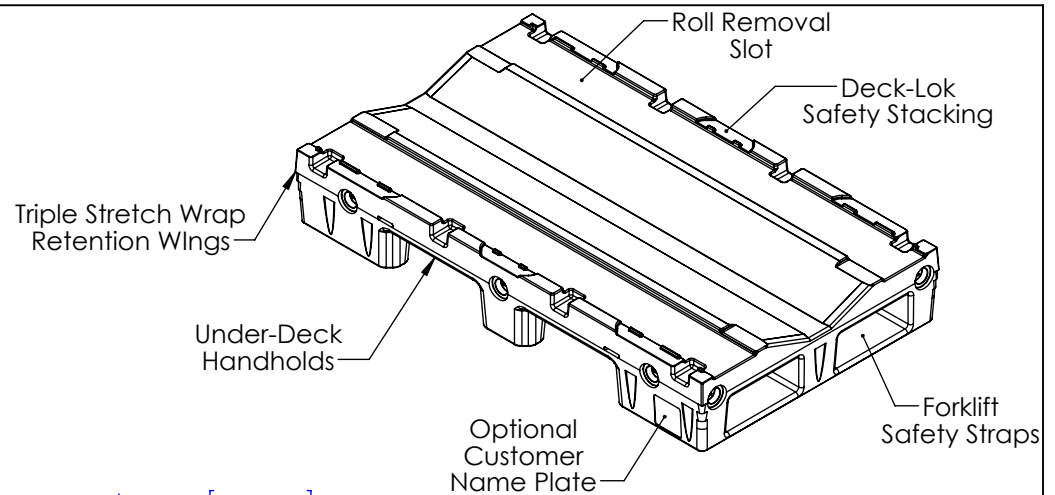

DO NOT SCALE		DRAWN BY	TITLE:	REVISION
STATUS:	Released	RS	Stratis Roll Pallet	A
© SNYDER INDUSTRIES INC., 2015				SHEET
ALL DIMENSIONS, DESIGNS, AND INFORMATION ON THIS PRINT MUST BE CONSIDERED PROPRIETARY TO SNYDER INDUSTRIES, INC. AND MAY NOT BE USED, COPIED, OR DISTRIBUTED WITHOUT WRITTEN PERMISSION OF AN OFFICER (OR HIS AGENT) OF THE FIRM.		+1(402)467-5221 www.pallets.com www.snydernet.com	PART NO.	1 OF 2
		RP3254S00-2SRRS	ENG. ID.	D003652

Steel Configurations:

RP3254S16-2SRRS

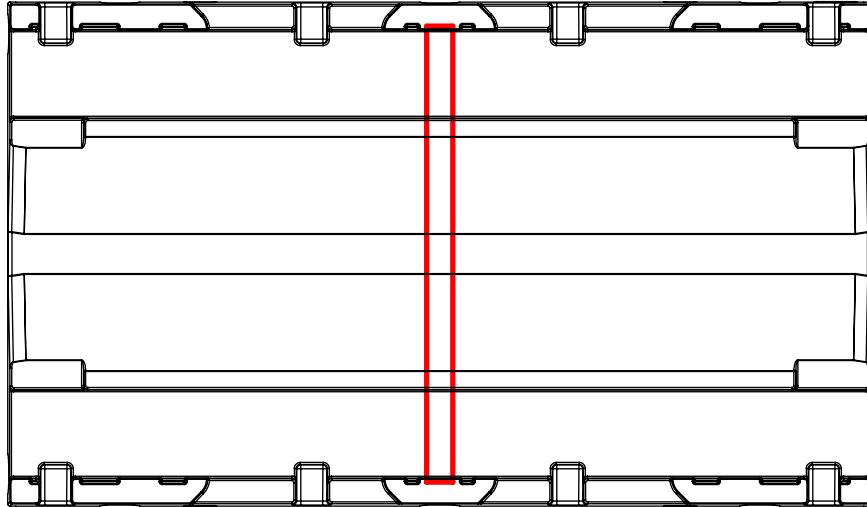

RP3254S32-2SRRS

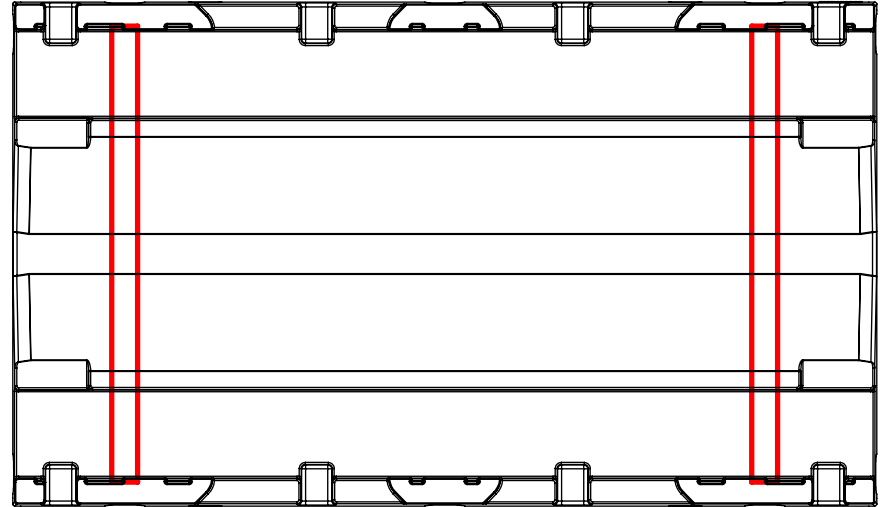

RP3254S32-2SRRSHD

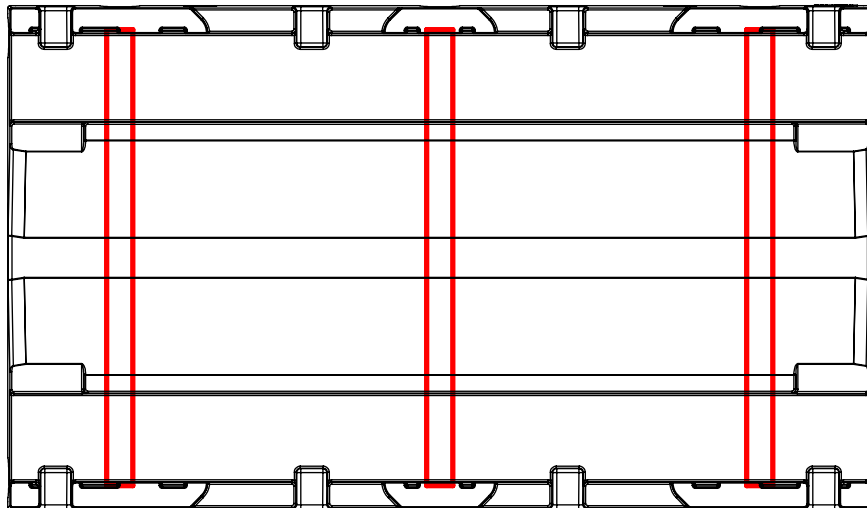

RP3254S54-2SRRS

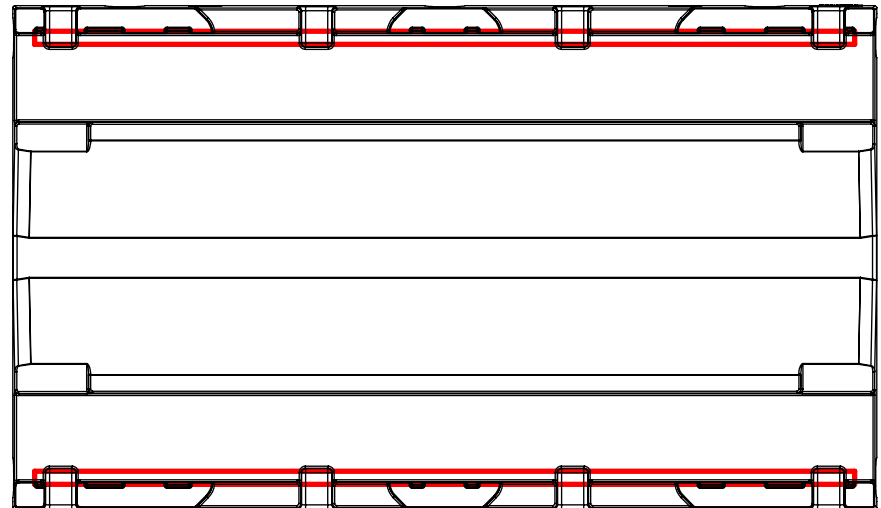

ALL DIMENSIONS ARE IN INCHES, NOMINAL, & SUBJECT TO CHANGE WITHOUT NOTICE.
 ALL DIMENSIONS ON MOLDED PARTS ARE SUBJECT TO A \pm 3% TOLERANCE, UNLESS SPECIFIED.

DO NOT SCALE		DRAWN BY	TITLE:		REVISION
STATUS:	Released	RS	Stratis Roll Pallet		A
© SNYDER INDUSTRIES INC., 2015			PART NO.		SHEET
ALL DIMENSIONS, DESIGNS, AND INFORMATION ON THIS PRINT MUST BE CONSIDERED PROPRIETARY TO SNYDER INDUSTRIES, INC. AND MAY NOT BE USED, COPIED, OR DISTRIBUTED WITHOUT WRITTEN PERMISSION OF AN OFFICER (OR HIS AGENT) OF THE FIRM.			+1(402)467-5221 www.pallets.com www.snyder.net		2 OF 2
			RP3254S00-2SRRS	ENG. ID.	D003652

