



## RHPTF4840-B14



### FEATURES

- ▶ Made from HDPE - Environmentally friendly and 100% recyclable
- ▶ Fully nestable to conserve space - Lowers return cost
- ▶ Lightweight for better Ergonomics - Worker friendly
- ▶ 4 way entry for forklift and pallet jack - Provides quick and easy handling
- ▶ Patented TriMax™ Design - Increases deck stiffness and durability
- ▶ Easy to clean
- ▶ Oval leg design - Minimizes damage caused by fork-tines
- ▶ Legs without drain holes

### OPTIONS

- ▶ Custom color(s)
- ▶ Custom stripe(s) - Only in 48" direction
- ▶ Leg drain holes available
- ▶ Logo plate placement
- ▶ Pocket recesses for label placement
- ▶ Anti-skid material - Significantly reduces product damage

# RHPTF4840-B14 Specifics

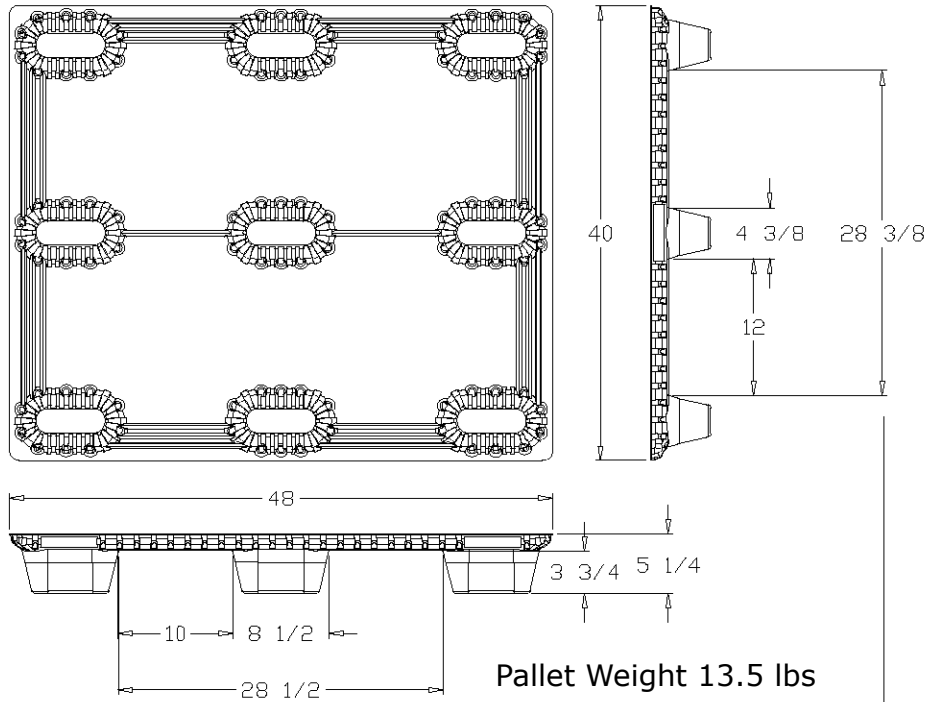

Oval 9 leg Design



In-transit Stability

Pallet Underside



Fully Nestable



<b>Load Rating</b>	<b>English</b>	<b>Metric</b>
Floor Load Rating . . . . .	3,000 lbs . . . . .	1,364 kg
Fork Load Rating . . . . .	1,500 lbs . . . . .	682 kg

## Packaging

Stack Height . . . . .	100"
# Pallets per Stack . . . . .	50
Qty Pallets per 48 ft trailer . . . . .	1,680
Qty Pallets per 53 ft trailer . . . . .	1,800
Qty Pallets per 20 ft container . . (540 min)	600
Qty Pallets per 40 ft container . . (1,200 min)	1,320
Qty Pallets per 40 ft HC . . . . .	1,160
Qty Pallets per 45 ft container . .	1,166

