



RHPTF4840-B21



FEATURES

- ▶ Made from HDPE - Environmentally friendly and 100% recyclable
- ▶ Fully nestable to conserve space - Lowers return cost
- ▶ Lightweight for better Ergonomics - Worker friendly
- ▶ 4 way entry for forklift and pallet jack - Provides quick and easy handling
- ▶ Patented TriMax™ Design - Increases deck stiffness and durability
- ▶ Easy to clean
- ▶ Oval leg design - Minimizes damage caused by fork-tines
- ▶ Legs without drain holes

OPTIONS

- ▶ Custom color(s)
- ▶ Custom stripe(s) - Only in 48" direction
- ▶ Custom logos
- ▶ Pocket recesses for label placement
- ▶ Anti-skid material - Significantly reduces product damage

RHPTF4840-B21 Specifics

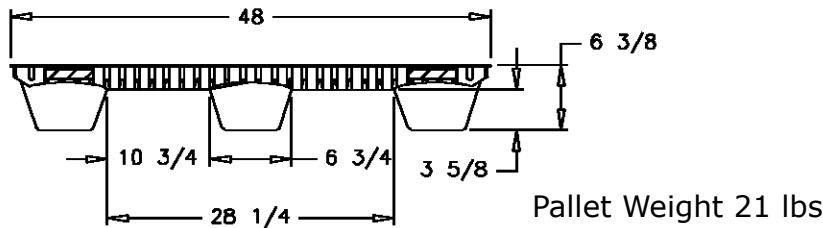
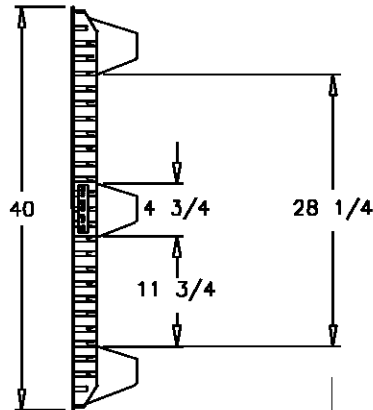
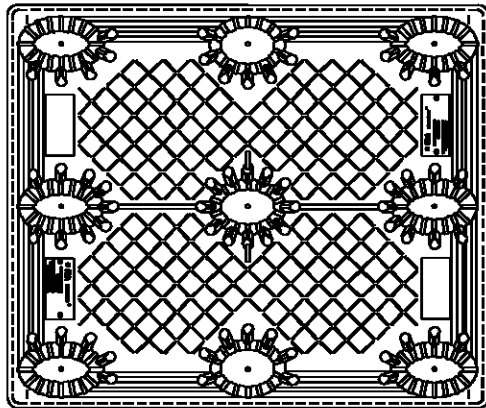

Oval 9 leg Design



In-transit Stability

Pallet Underside



Fully Nestable



Load Rating	English	Metric
Floor Load Rating	6,500 lbs	2,955 kg
Fork Load Rating	2,500 lbs	1,136 kg

Packaging

- Stack Height 100"
- # Pallets per Stack 36
- Qty Pallets per 48 ft trailer 1,008
- Qty Pallets per 53 ft trailer 1,080
- Qty Pallets per 20 ft container . . 324
- Qty Pallets per 40 ft container . . 720
- Qty Pallets per 40 ft HC 760
- Qty Pallets per 45 ft container . . 748

