

**CUSTOMER APPROVAL**

APPROVED FOR PRODUCTION AS DRAWN.  
 REVISE AS NOTED & RESUBMIT FOR APPROVAL.  
 SIGNATURE: \_\_\_\_\_  
 DATE: \_\_\_\_\_  
 DRAWING IS NOT VALID UNLESS SIGNED

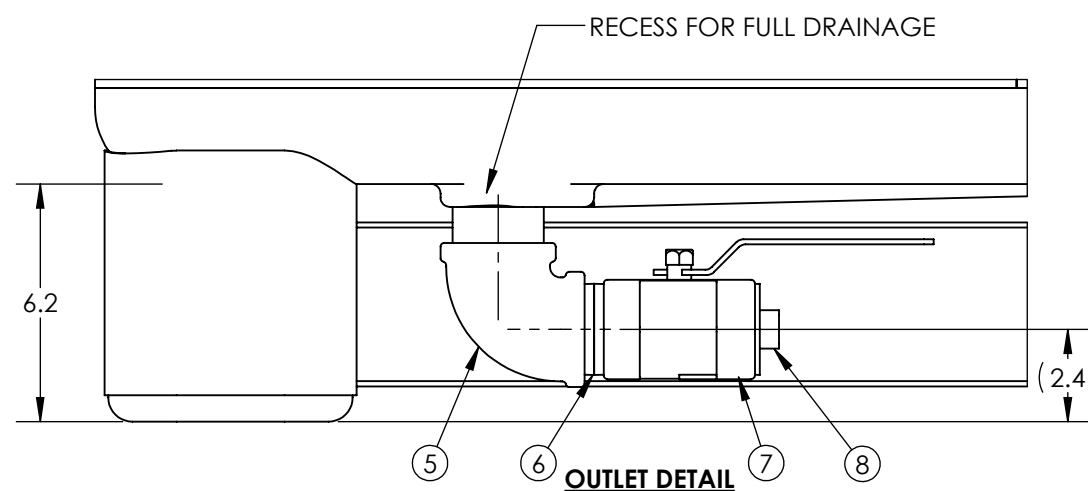
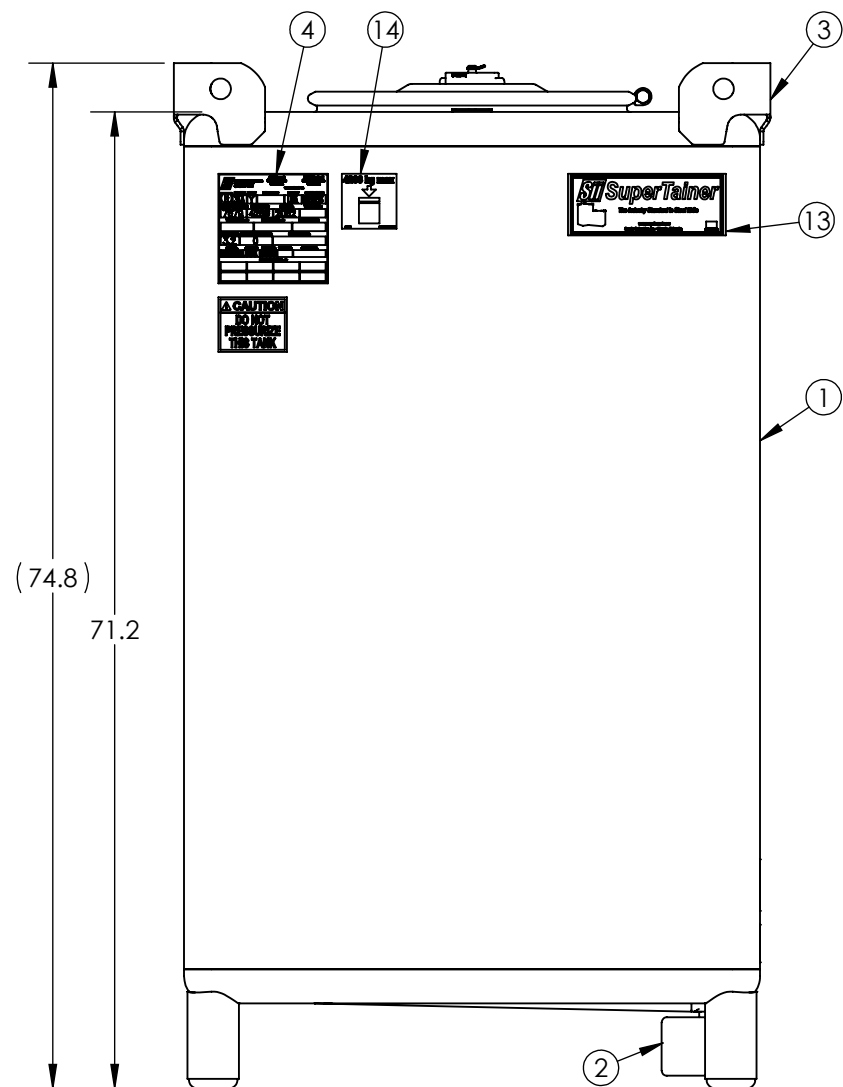
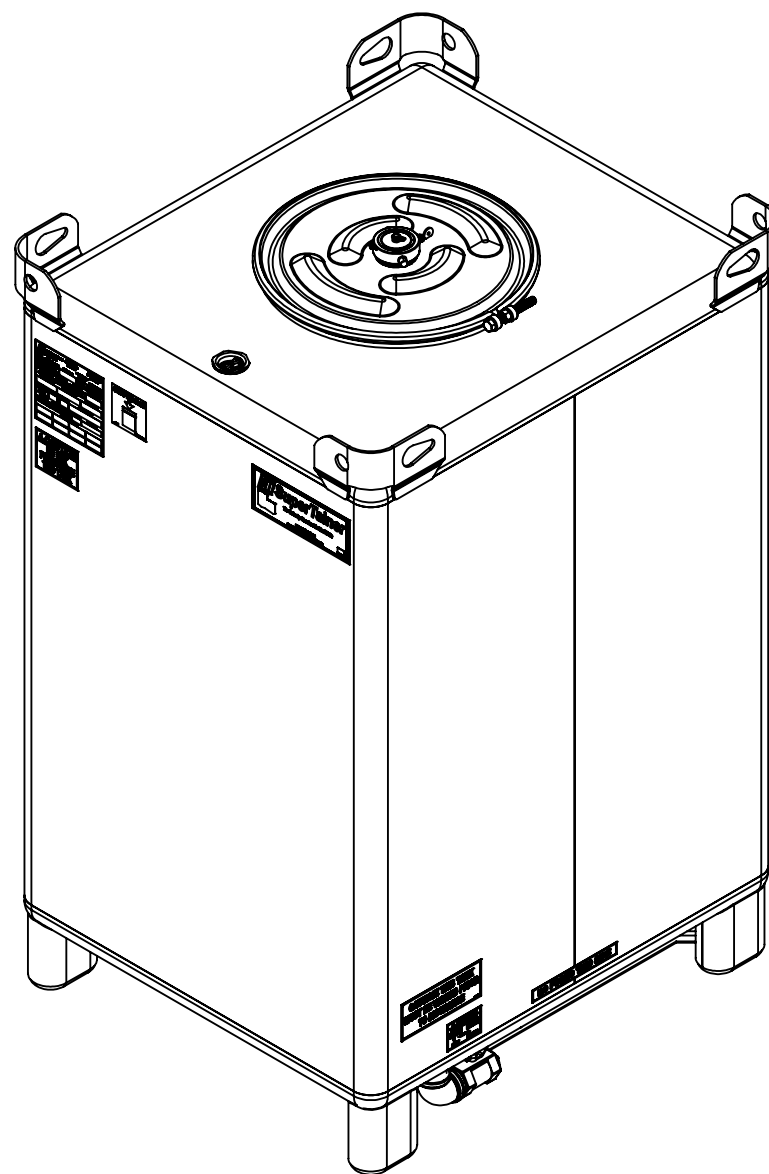
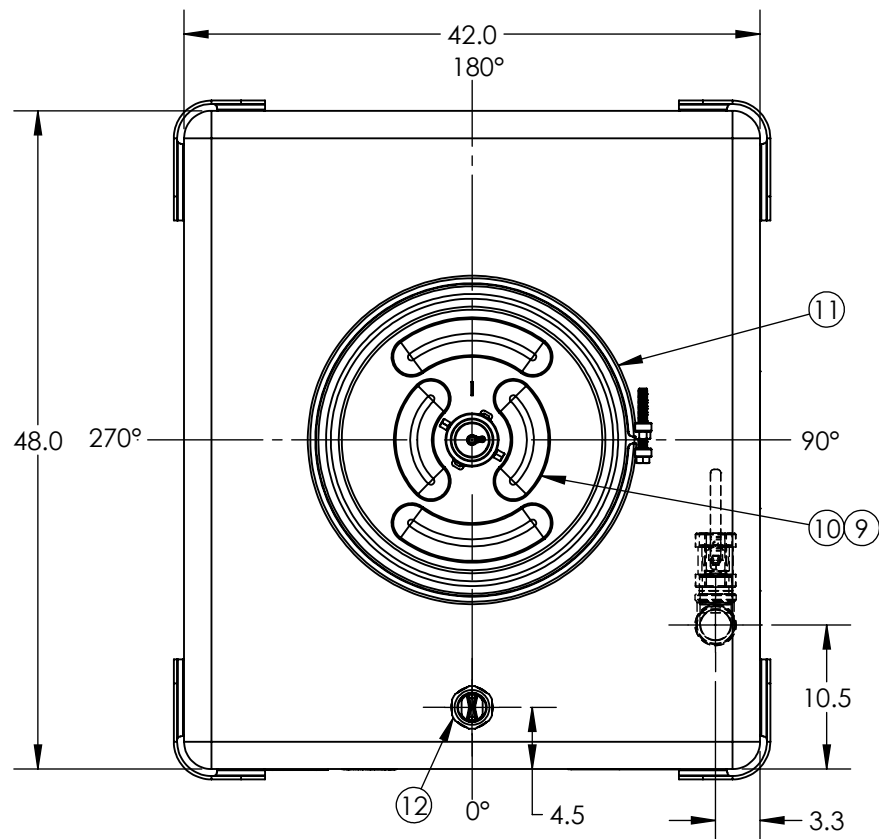

NOTES:

1. TANK IS DESIGNED AND CONSTRUCTED IN ACCORDANCE WITH U.N. SPECIFICATIONS.
2. TANK AND HEADS CONSTRUCTION OF 10 GA MATERIAL.
3. TANK IS AIR TESTED AT 3 PSI.
4. ALL WELDS CLEANED OF SLAG AND SPATTER.
5. TANK EXTERIOR TO BE PAINTED STANDARD TRANS BLUE.

ITEM NO.	QTY.	PART NUMBER	DESCRIPTION
14	1	99700364	DECAL STACK 550 SPRNTR
13	1	34701719	DECAL PKG SII STD SPRNTR REV-STEM
12	1	35901511	PLUG 2IN HEX HEAD WH EPDM GASKET 304SS
11	1	34701360	ASM BOLTED CLAMP RING 22-5/16 ZINC-PLTD
10	1	35901832	ASM LID 22-5/16 DOT 3IN FV W/TEF CS
9	1	33100387	GASKET 22-5/16 DIA 55 MS MULTISEAL EPDM
8	1	34200833	PLUG PVC 2IN NPT SQ HEAD
7	1	35400242	VALVE 2IN REV-STEM BV LOCKHNDL 316SS SII
6	1	35300474	NIPPLE CLOSE 2IN SCH80 CS
5	1	35300475	ELBOW 2IN 90DEG FEMALE THRD 150# CS
4	1	36500069	SNYDER IBC UN TAG 304SS
3	1	34900170	WELD ASM LIFT LUGS HEAVY DUTY CS
2	1	35901172	VALVE GUARD 4-1/4 X 43-1/4 X 10GA CS
1	1	34900118	TK 550 SPRNTR CS STD 6-3/16LEG

ITEM NO.	QTY.	PART NUMBER	DESCRIPTION	REVISION
DO NOT SCALE		DRAWN BY		AA
Released		KB		AA
© SNYDER INDUSTRIES INC., 2017				
STATUS: Released			TITLE: <b>ASM TK 550 SPRNTR 42X48 CS/TBLU SII FV</b>	
PART NO. <b>6984500B32204</b>			ENG. ID. <b>D007018</b>	
www.snyderinc.com			(402) 467-5221	

ALL DIMENSIONS ARE IN INCHES, NOMINAL, & SUBJECT TO CHANGE WITHOUT NOTICE.  
 ALL DIMENSIONS ON ROTATIONAL MOLDED PARTS ARE SUBJECT TO A ± 3% TOLERANCE.

ALL DIMENSIONS, DESIGNS, AND INFORMATION ON THIS PRINT MUST BE CONSIDERED PROPRIETARY TO SNYDER INDUSTRIES, INC. AND MAY NOT BE USED, COPIED, OR DISTRIBUTED WITHOUT WRITTEN PERMISSION OF AN OFFICER (OR HIS AGENT) OF THE FIRM.