

WITH OR WITHOUT
STEEL REINFORCEMENT

ROLLSTOCK
PRESSURE
RELIEF

UNDER-DECK
HANDHOLDS

SAFETY STACKING
FEATURE

CHAMFERED
FORK ENTRY

OPTIONAL
CUSTOMER
NAMEPLATE

STRETCH WRAP
RETENTION WINGS

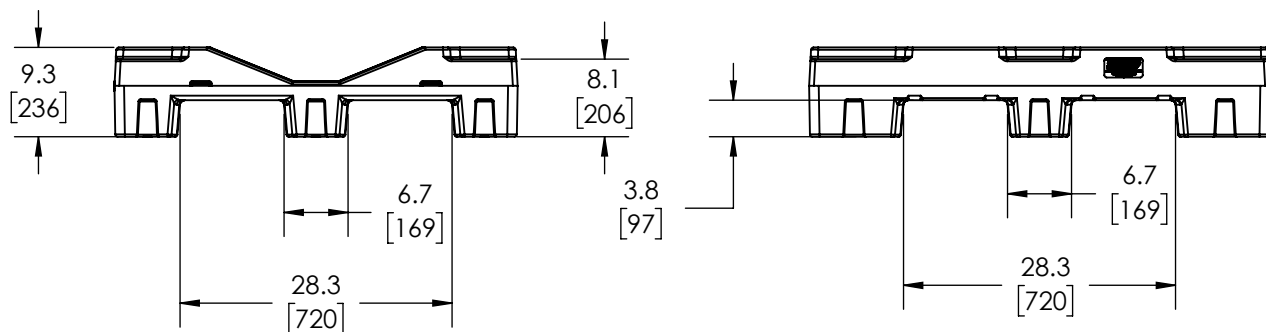
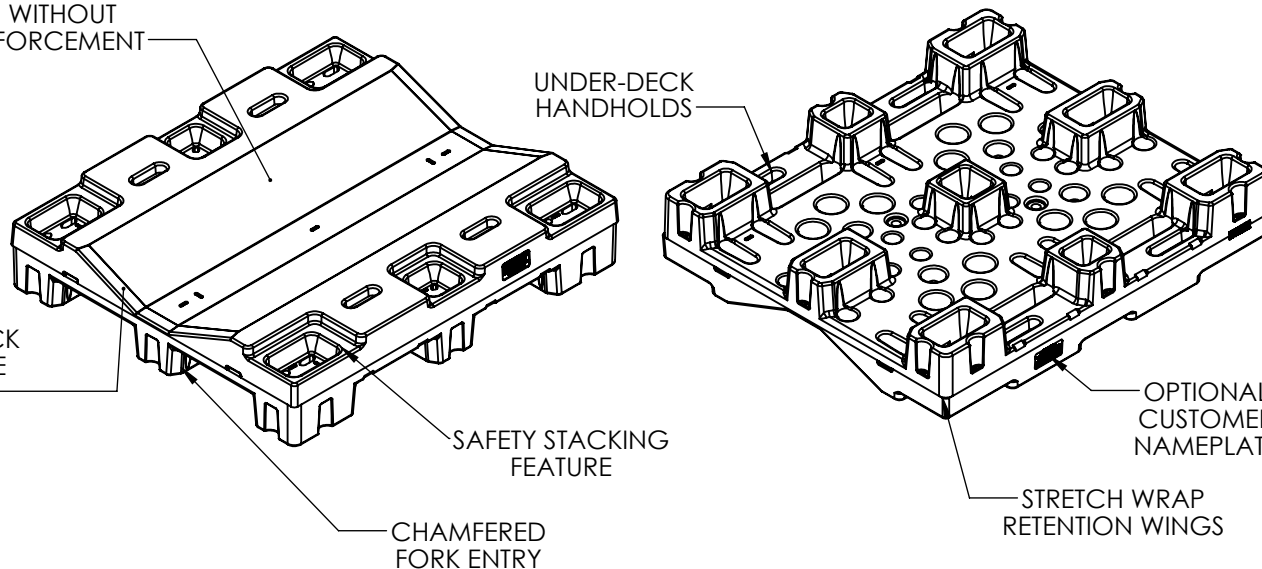
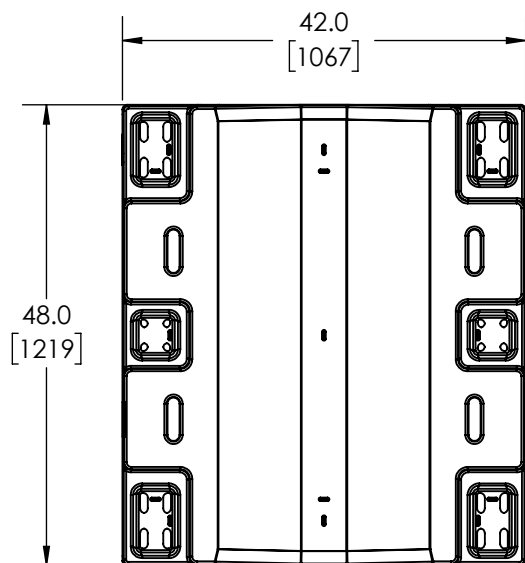

Ø 56.5
[1435]
MAX
Ø 24
[621]
MIN

CONTACT
POINTS

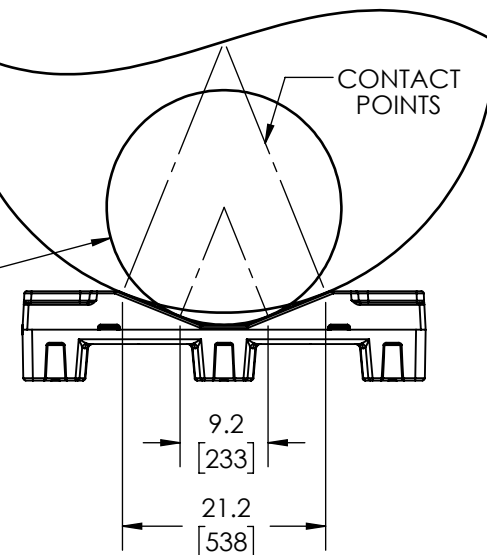

OVERALL DIMENSIONS

42.0" x 48.0" x 9.3"

1067mm x 1219mm x 236mm

PALLET FEATURES

- WITH OR WITHOUT STEEL REINFORCEMENT
- OPTIONAL CUSTOMER NAMEPLATE
- STRETCH WRAP RETENTION WINGS
- UNDER-DECK HANDHOLDS
- SAFETY STACKING
- ROLLSTOCK PRESSURE RELIEF
- CHAMFERED FORK ENTRY

**ALL DIMENSIONS ARE IN INCHES, NOMINAL, & SUBJECT TO CHANGE WITHOUT NOTICE.
ALL DIMENSIONS ON MOLDED PARTS ARE SUBJECT TO A ± 3% TOLERANCE.**

DO NOT SCALE		DRAWN BY	TITLE:	REVISION
STATUS: Released		BNC	Stratis Roll Pallet	A
© SNYDER INDUSTRIES, LLC, 2021				SHEET
<small>ALL DIMENSIONS, DESIGNS, AND INFORMATION ON THIS PRINT MUST BE CONSIDERED PROPRIETARY TO SNYDER INDUSTRIES, LLC, AND MAY NOT BE USED, COPIED, OR DISTRIBUTED WITHOUT WRITTEN PERMISSION OF AN OFFICER (OR HIS AGENT) OF THE FIRM.</small>		+1 (402) 467-5221 www.pallets.com www.snydernet.com	PART NO. RP4248S00	ENG. ID. D011478
				1 OF 1