

4-WAY ALUMINIUM PALLET - AP-4048-4W

APPROX WEIGHT: 33.42 lbs.
 DOES NOT INCLUDE WEIGHT OF POWER OR PACKAGING!!!

*** ANY ADDITIONS, DELETIONS, OR OMISSIONS MUST BE CORRECTED ON THIS DRAWING AS THIS DRAWING WILL BE CONSIDERED ALL INCLUSIVE ***

ALL GRAPHICS PROVIDED ARE FOR REFERENCE ONLY. IF CERTAIN DIMENSIONS ARE CRITICAL PLEASE VERIFY THOSE DIMENSIONS WITH YOUR SALESPERSON

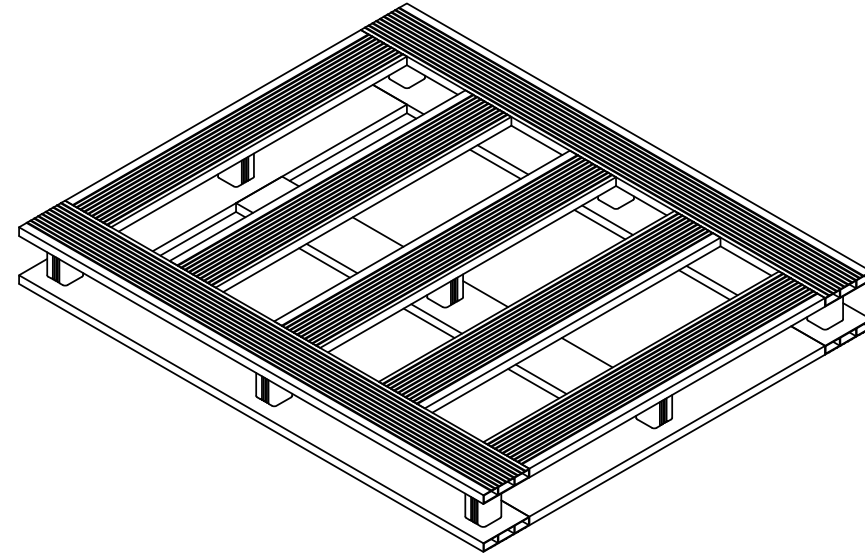
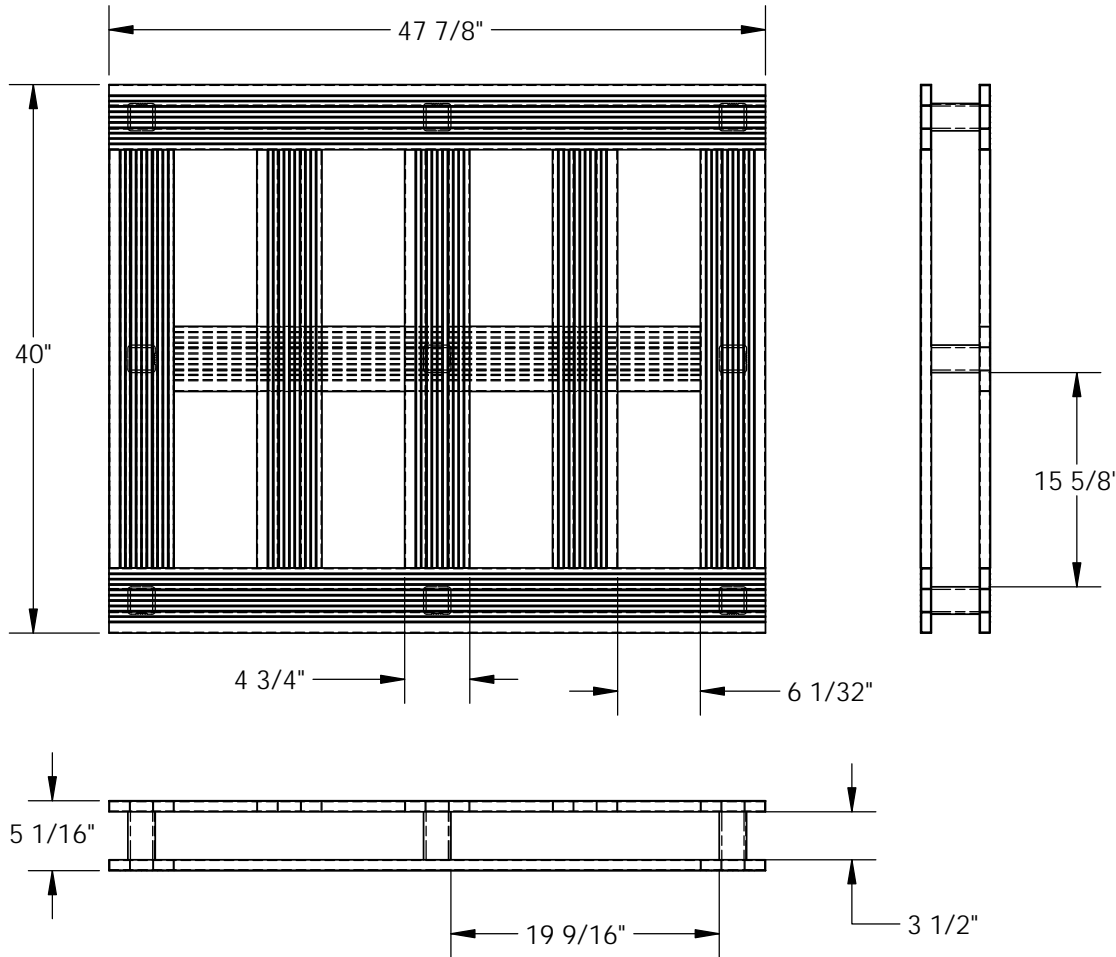

DIMENSION TOLERANCE $\pm 1/4"$

I, THE UNDERSIGNED, AGREE THAT THE PRODUCT AS REPRESENTED SATISFIES DESIGN AND DIMENSION REQUIREMENTS. I ALSO ACKNOWLEDGE MY DUTY TO CONFIRM PRODUCT AND INSTALLATION COMPLIANCE WITH ALL APPLICABLE FEDERAL, STATE AND LOCAL REGULATIONS AND STANDARDS.

ANY MODIFIED UNITS ARE NON-RETURNABLE

As drawn As marked

Signed: _____ Date: _____

Printed Name: _____

LEAD TIME WILL START UPON RECEIPT OF SIGNED APPROVAL DRAWING

STANDARD FEATURES

- MODEL NUMBER IS AP-4048-4W
- OVERALL WIDTH IS 40"
- OVERALL LENGTH IS 47 7/8"
- OVERALL HEIGHT IS 5 1/16"
- MAX STATIC CAPACITY IS 6,000 LBS
- MAX DYNAMIC CAPACITY IS 4,000 LBS
- MAX UNSUPPORTED CAPACITY IS 4,000 LBS
- TOP SLAT WIDTH IS 4 3/4"
- WELDED ALUMINUM CONSTRUCTION

SPECIAL FEATURES

NONE

FOR INTERNAL USE ONLY PROJECT SIGN OFF	
SALES	
ENG.	
FAB.	
POWER	

DISTRIBUTOR'S NAME:		P.O.#
VESTIL MANUFACTURING		X
DRAWN BY: T.BRUGGEMAN		DATE: 6/3/2014
REFERENCE: X		SCALE: 1:14
QUOTED LEAD TIME: X		QUOTE #
		X
		FILE NAME:
		31-007-198