

# PLASTIC PALLET/SKID - PLPS-4840

APPROX WEIGHT: 66.17 lbs.  
 DOES NOT INCLUDE WEIGHT OF POWER OR PACKAGING!!!

\*\*\* ANY ADDITIONS, DELETIONS, OR OMISSIONS MUST BE CORRECTED ON THIS DRAWING AS THIS DRAWING WILL BE CONSIDERED ALL INCLUSIVE \*\*\*

ALL GRAPHICS PROVIDED ARE FOR REFERENCE ONLY. IF CERTAIN DIMENSIONS ARE CRITICAL PLEASE VERIFY THOSE DIMENSIONS WITH YOUR SALESPERSON

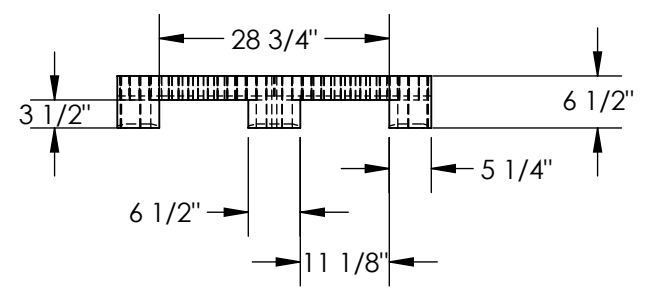
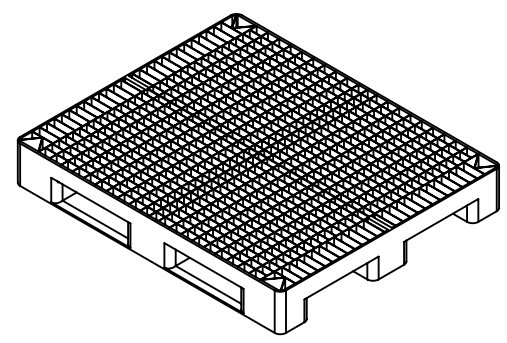
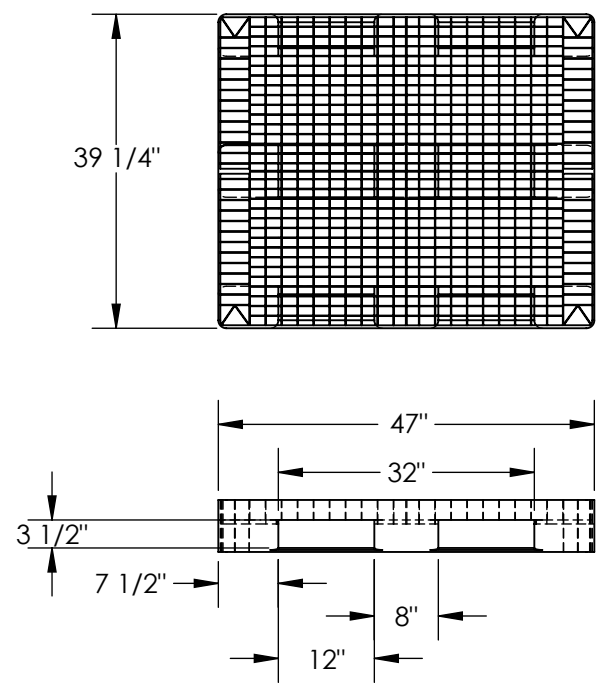

## STANDARD FEATURES

- MODEL NUMBER IS PLPS-4840
- OVERALL WIDTH IS 39 1/4"
- OVERALL LENGTH IS 47"
- OVERALL HEIGHT IS 6 1/2"
- FLOOR (STATIC) WEIGHT CAPACITY: 8,800 LBS
- FORK (DYNAMIC) WEIGHT CAPACITY: 2,200 LBS
- UNSUPPORTED PALLET RACK WEIGHT CAPACITY: 1,760 LBS
- FORK OPENINGS (W X H):
  - 12" X 3 1/2"
  - 11 1/8" X 3 1/2"
- BLUE IN COLOR

## SPECIAL FEATURES

NONE

A P P R O V A L	I, THE UNDERSIGNED, AGREE THAT THE PRODUCT AS REPRESENTED SATISFIES DESIGN AND DIMENSION REQUIREMENTS. I ALSO ACKNOWLEDGE MY DUTY TO CONFIRM PRODUCT AND INSTALLATION COMPLIANCE WITH ALL APPLICABLE FEDERAL, STATE AND LOCAL REGULATIONS AND STANDARDS.	
	<b>ALL SPECIAL UNITS ARE NON-RETURNABLE</b>	
	[ ] As drawn      [ ] As marked	
Signed: _____		Date: _____
LEAD TIME WILL START UPON RECEIPT OF SIGNED APPROVAL DRAWING		

DISTRIBUTOR'S NAME:		P.O.#
VESTIL MANUFACTURING		X
		W.O.#
		X
DRAWN BY: DEY	DATE: 12/30/10	SALES: X
REFERENCE: X	SCALE: 1:24	FILE NAME:
QUOTED LEAD TIME: X	QUOTE # X	30-007-206