

PLASTIC PALLET/SKID (HYGENIC) - PLPS-H

APPROX WEIGHT: 240.77 lbs.
 DOES NOT INCLUDE WEIGHT OF POWER OR PACKAGING!!!

*** ANY ADDITIONS, DELETIONS, OR OMISSIONS MUST BE CORRECTED ON THIS DRAWING AS THIS DRAWING WILL BE CONSIDERED ALL INCLUSIVE ***
 ALL GRAPHICS PROVIDED ARE FOR REFERENCE ONLY. IF CERTAIN DIMENSIONS ARE CRITICAL PLEASE VERIFY THOSE DIMENSIONS WITH YOUR SALESPERSON

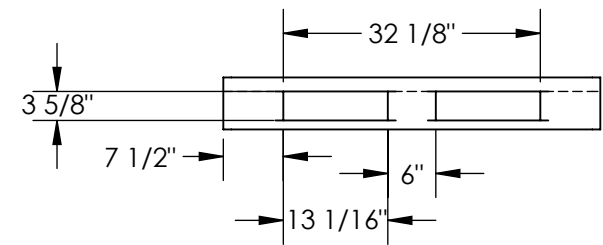
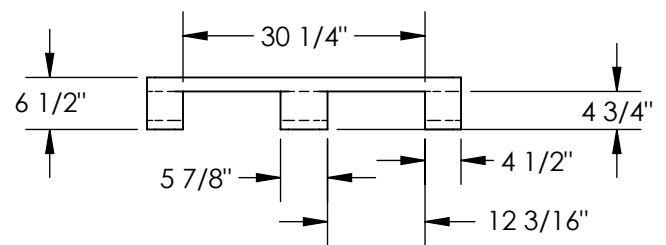
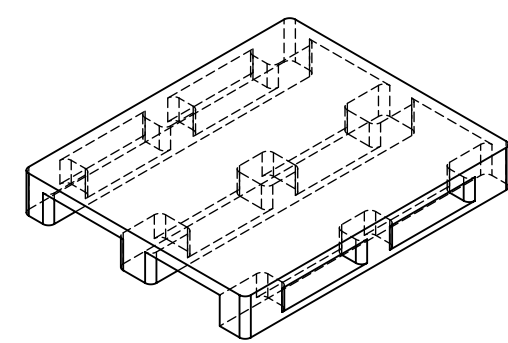
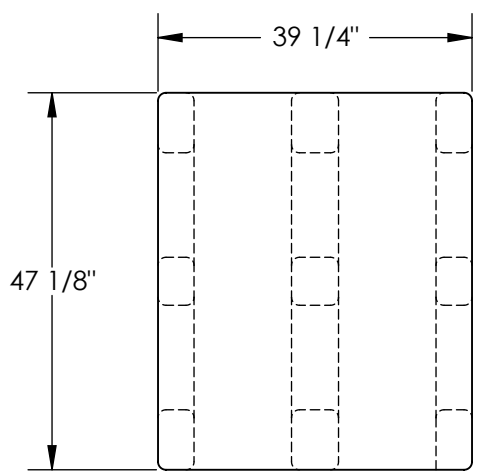

STANDARD FEATURES

- MODEL NUMBER IS PLPS-H
- OVERALL WIDTH IS 39 1/4"
- OVERALL LENGTH IS 47 1/8"
- OVERALL HEIGHT IS 6 1/2"
- FLOOR (STATIC) WEIGHT CAPACITY: 8,000 LBS
- FORK (DYNAMIC) WEIGHT CAPACITY: 3,300 LBS
- UNSUPPORTED PALLET RACK WEIGHT CAPACITY: 3,300 LBS
- FORK OPENING (W X H): 13 1/16" X 3 5/8"
- BLUE IN COLOR

SPECIAL FEATURES

NONE

A P P R O V A L	I, THE UNDERSIGNED, AGREE THAT THE PRODUCT AS REPRESENTED SATISFIES DESIGN AND DIMENSION REQUIREMENTS. I ALSO ACKNOWLEDGE MY DUTY TO CONFIRM PRODUCT AND INSTALLATION COMPLIANCE WITH ALL APPLICABLE FEDERAL, STATE AND LOCAL REGULATIONS AND STANDARDS. ALL SPECIAL UNITS ARE NON-RETURNABLE [] As drawn [] As marked	
	Signed: _____ Date: _____	
	LEAD TIME WILL START UPON RECEIPT OF SIGNED APPROVAL DRAWING	

DISTRIBUTOR'S NAME:		P.O.#
VESTIL MANUFACTURING		X
DRAWN BY: DEY		W.O.#
DATE: 11/19/10		X
REFERENCE: X	SCALE: 1:24	SALES: X
QUOTED LEAD TIME: X	QUOTE #	FILE NAME:
	X	30-007-200